



USER MANUAL

PROFESSIONAL SELF-CLEANING CRADLE ROTISSERIE OVEN

The SENSUP 6 and 9 series



SENSUP series self-cleaning rotisserie oven

Dear customer,

You have recently purchased a DOREGRILL rotisserie oven.

Thank you for choosing our equipment. We have been working hard to perfect the reliability, convenience and presentation of our products for over sixty years.

DOREGRILL is always at the cutting edge in our field. We pour all our skills and experience into our ovens to ensure that we meet your expectations by striving to combine comfort and safety.

In our range, you can also find a selection of display windows and cooking modules which you can use alongside your rotisserie oven.

In order to familiarize yourself with your new product as quickly as possible and to make the most out of it, please read this user manual carefully. It will enable you to use every function on your oven and extend the product's life.

We are always seeking to meet your expectations in regard to our products. Our technical team is on hand to guide you through installation and start-up, and reply to any questions and suggestions you may have. Please feel free to contact us or visit our website: WWW.1515DESIGN.COM

1515 DESIGN

405 North Oak Street, Inglewood CA 90302

Office: 310.671.0345

Email: info@1515design.com

We are constantly improving our products and services. To achieve this, we reserve the right to modify any technical, functional or visual characteristics relating to product development.

CONTENTS

1. General points	5
1.1. Labelling	5
1.2. The importance of the manual	5
1.3. Guarantee	6
1.4. Reserved rights	6
2. Technical description	6
2.1. General description	6
2.2. The control panel	7
2.3. Technical data	9
2.4. Intended use	9
2.5. General precautions	9
2.6. Electrical diagram	9
3. Transport and handling	9
3.1. Transport and delivery	9
3.2. Unpacking and handling	10
4. Installation and start-up	10
4.1. General instructions	10
4.2. Installation	10
4.3. Electrical connections	10
4.4. Plumbing	11
4.5. Cooking	11
5. Maintenance	11
5.1. Disassembly for cleaning	12
5.2. Reinforced component longevity	12
5.3. Automatic cleaning cycle	12
6. Tempered glass windows – main causes of breakage	13
6.1. Thermal shock	13
6.2. Impacts on the glass	13
6.3. Handling	13
7. Characteristics	15
8. Maintenance / Customer Service	17
8.1. Damage localisation	17
8.2. Specific repairs	17
8.2.1. <i>Changing a bulb</i>	17
8.2.2. <i>Opening the technical cabinet</i>	18
9. Illustrated composition table	20
9.1. Image 1 – Electrical diagram	20

INFORMATION FOR THE PRODUCT USER

1. General points

1.1. Labelling

This piece of equipment complies with all applicable European directives. As such, the EC logo appears on the information panel and a compliance declaration is attached to the present document.

- **Manufacturer name**
- **EC labelling**
- **Equipment model (SERIES)**
- **Machine serial n°**
- **Voltage**
- **Year of manufacture**

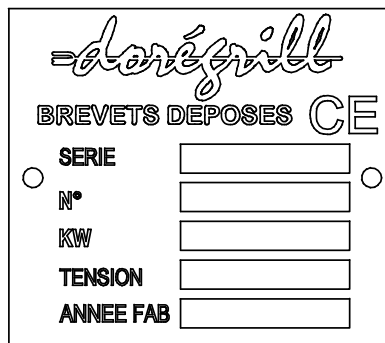

Fig. 1 (EC labelling)

This panel is attached to the left hand side of the rotisserie oven, on the bottom of the technical cabinet door.

1.2. The importance of the manual

The present set of user instructions aims to provide users of this equipment with all the information they need to make the most out of their rotisserie oven, extend its useable life with regular and appropriate cleaning, solve minor problems and incidents which often do not require specialist intervention, and avoid, by following the warnings and recommendations, any risk of injury to the users.

This manual, valid for the SENSUP model, is an integral part of our rotisserie ovens, and must remain accessible to the operators.

The manufacturer is not responsible for any damage caused to people, animals or property caused by misuse of the equipment or non-adherence to the rules included in the manual.

IMPORTANT: This equipment is for professional use. As such, and in order to avoid any danger, it must only be used by qualified personnel. It must be installed in compliance with current regulations.

1.3. Guarantee

The manufacturer guarantees that the rotisserie ovens listed have been subject to tests and trials in our workshops.

The guarantee for these rotisserie ovens is **12 (twelve) months**. Please see the Guarantee Certificate attached to your invoice.

The use and/or replacement of components by non-original parts will void the guarantee and release the manufacturer from all responsibility.

1.4. Reserved rights

The reserved rights concerning this “*SENSUP series self-cleaning cradle rotisserie oven user manual*” remain the property of the manufacturer. No part of the manual may be reproduced or distributed without prior written authorization by the manufacturer.

2. Technical description

2.1. General description

The rotisserie oven is generally mounted on a trolley (1) fitted with castors (4 castors, including 2 with brakes)

It comprises:

- A structure (*raised base, lateral and rear cladding*) made from stainless steel,
- Standard stainless steel cradles,
- A removable cradle support to facilitate cleaning,
- On the lower part, a stainless steel fat tray fitted with a drainage plug,
- A double window, made from: a tempered water-resistant window and a tempered heat-protection window (the windows are printed with the word “Rotisserie”; These two windows form a single unit and are held together using magnets. They remain closed the same way).
- 1 water-resistant quartz lamp-projector with a maximum power of 300 Watts set into the ceiling and which provide powerful lighting. They are protected by tempered glass screens.
- A touch-screen glass control panel.

2.2. The control panel

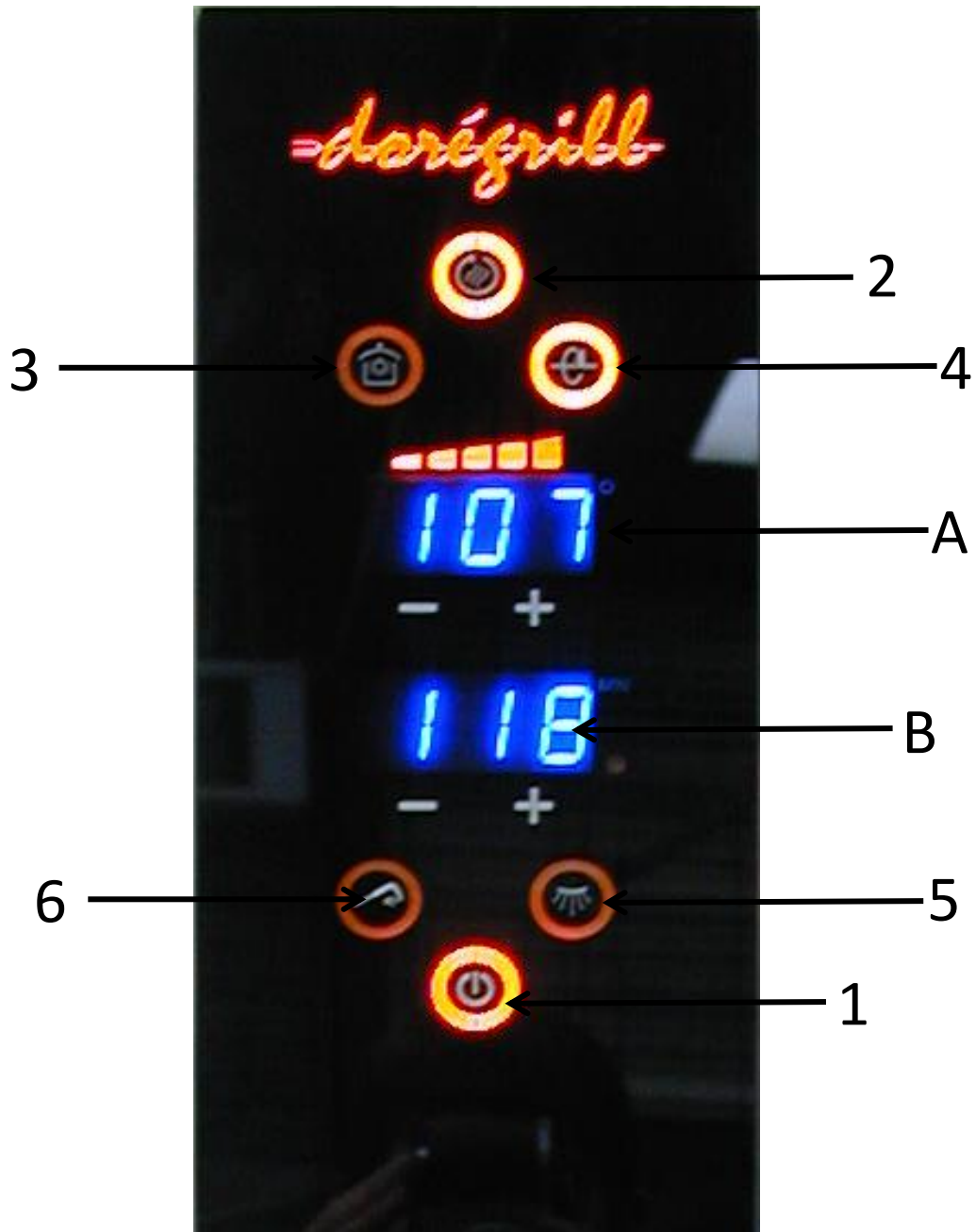

- The function buttons
- 1. Illuminated power button
- 2. Illuminated "cooking" button
- 3. Illuminated "maintain temperature" button (rotisserie oven maintains the temperature after cooking)
- 4. Illuminated motor rotation button
- 5. Illuminated "cleaning cycle" button
- 6. Illuminated temperature probe button (optional)
- A. Temperature display
- B. Time display

1. Illuminated power button
Touch the button for a few seconds to activate or switch off the commands on the control panel.
2. Illuminated cooking button
Touch to start cooking: timer activated
3. Illuminated lighting and maintained temperature button
Touch (*on/off*)
4. Illuminated motor rotation control button
Touch to start the motor (*on/off*)

- **Temperature display (A)**

- Temperature graduation indicators (LED). Five different settings. These lights indicate the heating level selected (“cooking” or “maintain temperature” modes)
- Increase the temperature: press this button repeatedly to increase the cooking temperature (maximum: 5 LEDs)
- Decrease the temperature: press this button repeatedly to decrease the cooking temperature (maximum: 1 LED)
- Cooking mode

Number of LEDs	0 LEDs	1 LED	2 LEDs	3 LEDs	4 LEDs	5 LEDs
Approximate temperature	65°C	100°C	135°C	170°C	200°C	230 °C

- Maintain temperature mode

Number of LEDs	0 LED	1 LED	2 LED	3 LED	4 LED	5 LED
Approximate temperature	65°C	75°C	80°C	85°C	90°C	95°C

- Temperature display:
- Indicates the ambient heating volume temperature
- **Important:** Cooking adjustment recommendation after a 5 LED factory test.
 - **Time display (B)**
- Increasing the cooking time: press this button repeatedly to increase the cooking time (max: 120 minutes)
- Reducing the cooking time: press this button repeatedly to decrease the cooking time.

5. Illuminated cleaning cycle start button.
Runs for 15 minutes.

Important: The cleaning cycle must be started when the oven is **COLD** (max; 40°C). Allow your oven to cool before cleaning.

6. Optional temperature probe. Touch the illuminated button (for the chicken's core temperature) and the display will start to blink. The temperature can now be taken.

2.3. Technical data

The table on page 15 lists the technical data for our **SENSUP** model rotisserie oven.

2.4. Intended use

Our rotisserie ovens are designed to cook meat and poultry as part of the warm product offer of shops and caterers in the food industry.

2.5. General precautions

This equipment is not suitable for use by people (including children) with reduced physical, sensory or mental capacities, or by people with insufficient knowledge or experience unless they are supervised or instructed in equipment safety by a person responsible for their safety.

2.6. Electrical diagram

See illustrated Composition Table

3. Transport and handling

3.1. Transport and delivery

Our rotisserie ovens are calibrated, tested and checked in our workshops. They are carefully packaged in order to guarantee that they arrive at their destination in the best possible conditions.

Once the equipment is unpacked, ensure that it has not been damaged during transport. If this is the case, any damages must be recorded and reported to the transporter. The reserves stipulated in the Delivery Document must be followed, within 48 hours of delivery, by a registered letter to the transporter and the forewarned retailer.

3.2. Unpacking and handling

When unpacking your oven, do not pierce the bubble wrap packing with an object which could damage any of the components.

The oven can be moved around flat surfaces using its castors.

If a forklift truck must be used to lift the oven, it **must** be passed under the roof of the oven, once the FRONT and REAR windows have been kept open.

4. Installation and start-up

4.1. General instructions

The rotisserie oven must be installed (in terms of position and connection) by authorized personnel with the necessary technical and professional skill to install the oven according to the current standards in the country of use.

4.2. Installation

Unpack the rotisserie oven, cradles and accessories.

Install the rotisserie oven at a safe distance from any combustible material (*wood, plastic, etc.*). In the event that they cannot be removed, they must be protected by insulation.

Important: Leave an air gap of at least 150mm behind and to the sides of the rotisserie oven to ensure sufficient ventilation and protection for nearby equipment and walls, as well as for the oven's tempered glass windows.

4.3. Electrical connection

Check that the available voltage matches the characteristics listed on the information panel at the bottom of the left side of the oven.

The oven must be connected to the power supply using a plug **which must be earthed**.

The connection must be made using a 400 V + N + T tri-phase plug. Check that there are no errors in the connection (inversion of earth and neutral, for example).

Refer to the current electrical standards applicable in the country of use.

Important: The manufacturer may not be held responsible for any accidents following an absent or faulty earth connection, or any other inappropriate installation.

Important: It is formally prohibited to place trays or any other object on top of the rotisserie, or to obstruct the exhausts or ventilation zones in any way.

▪ **Preparation**

Voltage required: 400 + Neutral +Earth

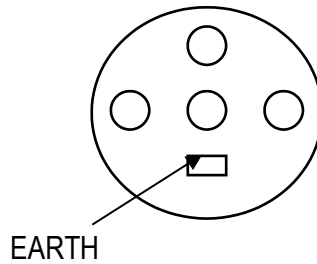

If the rotisserie oven is destined for outdoor use, **use waterproof plugs.**

4.4. Plumbing

It is essential to allow for a **cold water** supply (diameter 15/21) near the rotisserie oven. The oven will be connected to the network using a standard flexible hose with a standard female “watering” type connector. The machine comes fitted with a male connector piece, located under the oven.

Important: It is necessary to install a water softener upstream of the oven in order to avoid the accumulation of lime scale and preserve the electromagnetic valve and the reinforced components.

Every time you cook, ensure that the tray is covered with water to ensure sufficient humidity (at least 1cm covering the entire surface of the tray).

4.5. Cooking

- Place the chickens in the cradles after pricking and seasoning them.
- Switch the machine on by pressing the illuminated button **1**
- Choose the temperature using the + and – buttons.
(Normally 5 LEDs for cooking chickens)
- Choose the cooking time using the + and – buttons.
- Press **button 2** to start cooking and activate the timer.

5. Maintenance

Important:
Never use a high pressure cleaning system on the product.
Only use “Oven Special” cleaning products which are approved for use on food equipment
(1)

The SENSUP series rotisserie ovens are designed to simplify the cleaning process:

- The humidity and ventilation reduce the “baked-on” grease effect.

¹DECAGRILL, distributed by DOREGRILL is recommended for cleaning your rotisserie oven

- The Scotch Brite stainless steel helps prevent fat from sticking
- As the heating elements are located near the top of the oven, most of the smoke associated with rotisserie ovens is neutralized.
- All of the components can be disassembled for fast, complete and easy cleaning.
- The independent double windows ensure both a panoramic view of the cooking process and direct access to the interior.

5.1. Disassembly for cleaning

- **Machine interior: accessories**

Remove the cradles and their support.

To remove the Rotisserie rotating access, the drive shaft must be vertical.

- **Machine interior: ventilation housing attached to the inside of the roof**

This cleaning operation must be performed at least **once per week**, and more for frequent use.

- Start by unscrewing the 4 wing nuts
- Remove the stainless steel protective housing to access the fan
- This housing and its ventilation holes must be thoroughly cleaned
- Remove the fan by unscrewing the inverted wing nut (turn it clockwise)
- Soak the housing and the fan until clean, and clean the ceiling.
- Re-assemble the components by following the same procedure, but in reverse.

- **Cleaning the double windows**

Thanks to the separate opening systems for both windows, you can clean the entire glass surface.

5.2. Reinforced component longevity

All of our reinforced heating elements are “Incoloy” quality.

They are located at the top of the oven, on either side of the extractor fan.

Despite their quality, and taking into consideration the power of new cleaning products, these elements may be damaged or weakened. To avoid premature aging for your equipment, we recommend protecting these elements with aluminium foil while spraying your cleaning product.

Before switching the oven back on, carefully wipe the elements with a **wrung out** (no longer wet) sponge to remove all traces of cleaning product.

5.3. Automatic cleaning cycle

This cycle facilitates cleaning by generating steam for 15 minutes within the body of the oven.

Procedure:

- Connect the rotisserie oven to the plumbing using a flexible hose with a standard stainless steel female connector piece, attaching it to the male connector under the oven
- Turn on the tap
- Remove all the accessories which need to be hand-washed (spits, cradles and central support if necessary)
- Switch off all programmes and functions. Only the light 1 must be on (*see plan on page 7*)
- Start the cleaning cycle (button 5). The “Time” display will show 15 minutes
- At the end of the cycle, run a sponge over the entire surface
- Empty the fat tray using the drainage plug. Do not forget to place a container underneath.

Important:

It may sometimes be necessary to run the cleaning cycle a second time, especially if using the oven intensively.

Please note that there is no need to use a cleaning product.

Warning: The use of bleach or other chlorine-based product will cause the stainless steel to oxidize. We may not be held responsible for this.

6. Tempered glass windows – main causes of breakage

6.1. Thermal shock

There must not be a temperature difference greater than 80°C between any two points on the glass. When this occurs, the rupture point is reached and the glass can explode at any moment.

E.g. Cleaning a hot window with a cold sponge.

6.2. Impacts on the glass

When a tempered glass window receives an impact, especially on the edge or the corner, a small piece of glass, often the size of a pin-head, may break off.

After this, the molecular **equilibrium** of the glass is broken. The glass will inevitably break, whether in the hour or within a few days.

This kind of impact may occur when unpacking the equipment, or when the user accidentally strikes the edge of the glass with an accessory (spit, basket, fat tray, etc.) during installation.

6.3. Handling

Ill-timed and frequent movement (e.g. rolling the oven onto the pavement every day) will prematurely weaken the glass surfaces.

Important:

Glass, whether tempered or not, is a fragile material which must be handled with care. It is sensitive to impact, **and in no event can break by itself without one of the aforementioned causes.**



INFORMATION FOR THE PRODUCT INSTALLER

7. Characteristics

Dimensions	SENSUP 6	SENSUP 9
Total width	1020mm	1020mm
Total depth	775mm	955mm
Height		
- of the rotisserie unit	910mm	1090mm
- mounted on the trolley	1700mm	1780mm
Total empty weight	168kg	239kg
Technical components		
Cradles		
Number	6	9
Useful length	725mm	725mm
Drive motors		
Number	1	1
Ambient lamps		
Number	2	2
Voltage, unitary power	230V/300V	230V/300V
Fan		
Number of hot air fans	2	2
Number of hot air housing units	1	1
Total system power	11kW	16kW
Voltage	400V + N + T	400V + N + T
Power supply cable		
Cross-section	5 x 2.5mm ²	5 x 2.5mm ²
Plug: 4 pins + earth	Yes	Yes
Capacity ⁽²⁾		
Capacity in number of chickens <i>depending on size</i>	20/30 chi.	30/45 chi.

²These capacities are given as a guideline only and depend on the size of the chickens.



MAINTENANCE

8. Maintenance / Customer Service

Any interventions on your oven must be performed by a qualified professional.

8.1. Damage localisation

The aim of this part is to list the main problems that the user may confront, give the possible causes and provide the resources to solve them without needing outside help.

Defect observed	Possible causes	Solutions
Electrical circuit		
The touchscreen does not light up	- No electrical power	- Connect the plug to the socket. Reset the circuit-breaker and change the fuse on the oven. If the problem persists, contact your installer.
1 ambient lamp is not working	- Defective bulb	- Change the bulb
The cradles do not turn	- Defective motor	- Call the installer
Very long cooking times	- Defective heating elements	- Check the elements

8.2. Specific repairs

8.2.1. Changing a bulb

This operation can be performed by the user.

Warning: Before changing a hot lamp, wait a few minutes for it to cool down in order to avoid burning yourself.

Disconnect the rotisserie oven's power supply.

With a number 7 Allen key, unscrew the screws and remove the stainless steel frame.

Unscrew the unit, remove the defective bulb and replace it with an identical, 300W max bulb. Never hold it in your bare hands; always use a paper or a clean cloth. The slightest fingerprint or trace of oil may render the bulb unusable.

If the bulb seems unclean, clean it with alcohol and a soft cloth.

Put the glass screen back in place and replace the stainless steel frame.

Fig. 1

8.2.2. Opening the technical cabinet

The technical cabinet is located on the left of the rotisserie oven, behind the control panel. It enables you to access the various components of the electrical circuits.

This operation must only be performed by qualified personnel.

Before opening the housing, disconnect the rotisserie oven from the power supply. Using a screwdriver, undo the screw holding the outer panel in place then remove it. Once the intervention is finished, it is important to replace this panel and reinsert the screws.



ILLUSTRATED COMPOSITION TABLE

9. Illustrated composition table

9.1. Image 1 – Electrical diagram

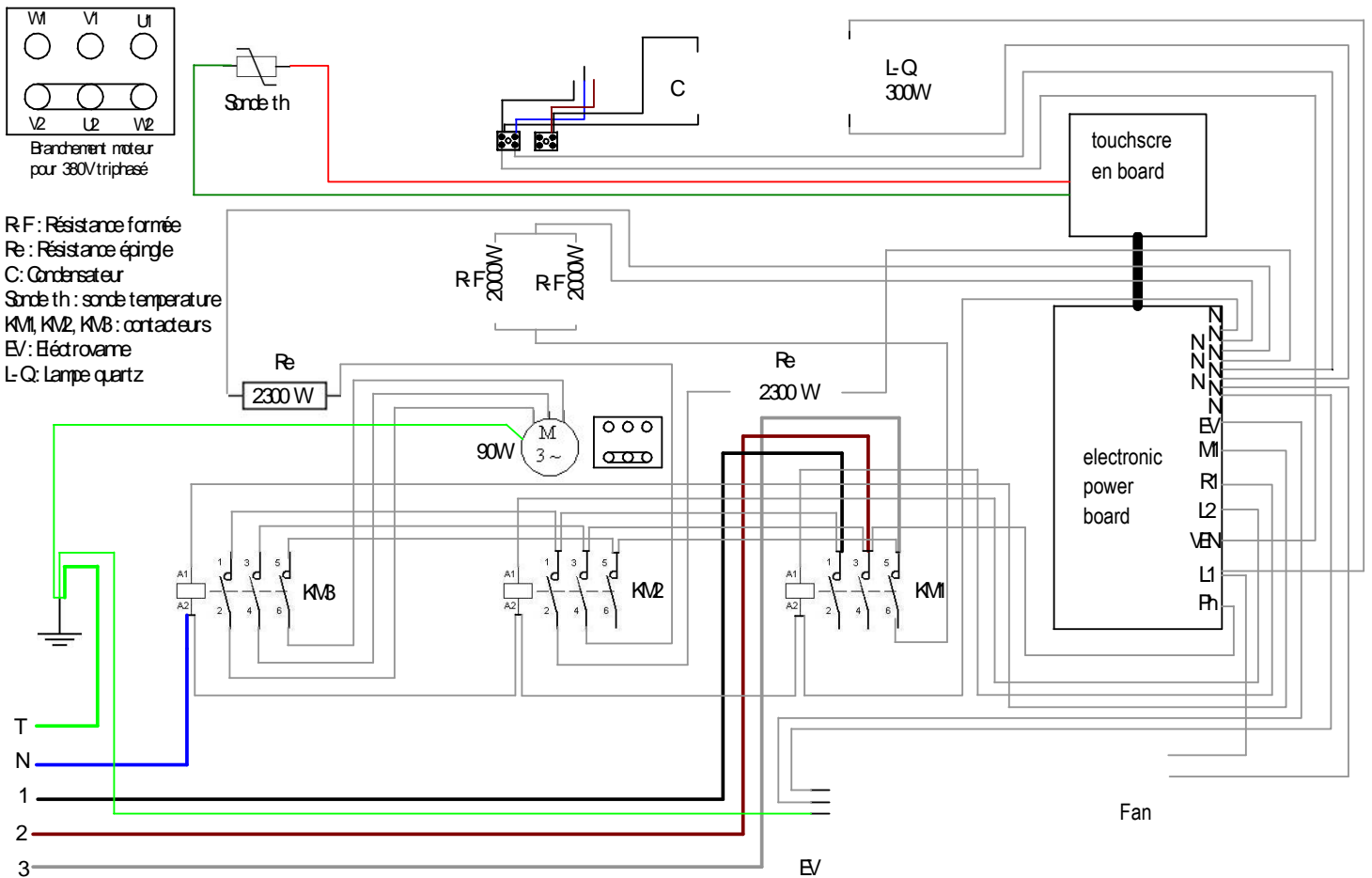

- RF = shaped resistor
- Re = pin resistor
- C = condenser
- Sonde th = temperature probe
- KMA, KM2, KM3 = contactors
- EV = electromagnetic valve
- L-Q = Quartz lamp



SENSUP S6
Positioning of a fat and cleaning-water drainage hole

(for the design of a base unit)
Plan for a hole in the unit with a min. 80mm hole

